

The importance of applying an appropriate approach to modelling wastewater treatment plants

Alma Dzubur* and Amra Serdarevic^a

Department of Sanitary Engineering and Department of Environmental Engineering, Faculty of Civil Engineering, University of Sarajevo, Patriotske lige 30, Sarajevo, Bosnia and Herzegovina

(Received August 29, 2021, Revised September 9, 2021, Accepted October 11, 2021)

Abstract. Wastewater treatment plants (WWTPs) are designed and built to remove contaminants from wastewater. WWTPs are composed of various facilities equipped with hydro-mechanical and electrical equipment. This paper presents a comparison of two different approaches for WWTPs modelling. Static modelling is suitable for determining the dimensions of facilities and equipment capacity. The special significance of this approach is for the design of new plants, i.e., when a very small number of input data on the quantities and composition of the influent wastewater is available. Dynamic modelling is expensive, time consuming and requires great expertise in the use of simulators, models and very good understanding of the treatment processes. Also, dynamic modelling is very important to use for optimization, consideration of future scenarios and also possible scenarios on the plant. The comparison of two approaches was made on the input data from the biggest and most important plant in Bosnia and Herzegovina (B&H)-WWTP Butila (Sarajevo). The main idea is to show the differences between two demanding accesses. It is important to know how to apply an adequate approach to research and solve the set task. The II phase of the plant Butila, which includes the removal of nutrients, is planned in several years and therefore the importance of research has increased.

Keywords: different approach; dynamic; input data; modelling; steady state; wastewater treatment

1. Introduction

In order to protect water and the environment in general, it is necessary to treat wastewater from population and industry. For treating wastewater, the contained pollutants need to be reduced in accordance with the prescribed restrictions of the legislation. Emission limits for the discharge of wastewater into watercourses are defined according to key quality parameters in relation to the capacity of the WWTPs. It is common to divide plants into different categories (classes).

WWTP categorization (classification) is contained in wastewater legislation. Usually, plant categorization is expressed in two ways: pollutant equivalent (PE) and daily load of pollutants in kg/day (most often according BOD₅). The European Directive 91/27/271 (Urban Waste Water Directive) and B&H legislation categorize the plants in small and large. However, the developed countries with a population connection rate to the sewage system and wastewater treatment over 90%, have often in their legislation more than two categories. One such example is the German

*Corresponding author, Assistant Professor, E-mail: a_dzubur@hotmail.com

^aAssociate Professor, E-mail: amraserdarevic11@gmail.com

“AbwV” regulation (<https://www.gesetze-im-internet.de/abwv/AbwV.pdf>), where the plants are divided into 5 groups (GK1-GK5). According the 5 categories i.e., size range of WWTP (GK - “Größenklasse”), the values of emission limit are prescribed there, with stricter conditions for large vs. small plants of discharging effluent into watercourses.

WWTPs classification into more than two categories enables better systematization of treatment technologies. Also, by a more detailed classification of WWTPs according to capacity, it is possible to define stricter effluent conditions for larger plants. This is important because higher flow at large WWTPs results in increased pollution inputs to watercourses.

The size of the WWTP also influences the choice of the technological procedure used to remove pollution from wastewater. Various municipal wastewater treatment technologies are used in the world. The most common is the conventional technology with activated sludge. Usually, unconventional treatment technologies and technologies with activated sludge in fixed growth are recommended for small plants, while conventional technology with activated sludge in suspended growth system, SBR, MBR etc. (Metcalf & Eddy 2014) are recommended for large plants.

Also, depending on many factors, including the size of the WWTPs and the chosen technological process, the design of facilities and technological equipment can be based on different approaches. However, the calculation and dimensioning of WWTPs can be static (steady state) and dynamic

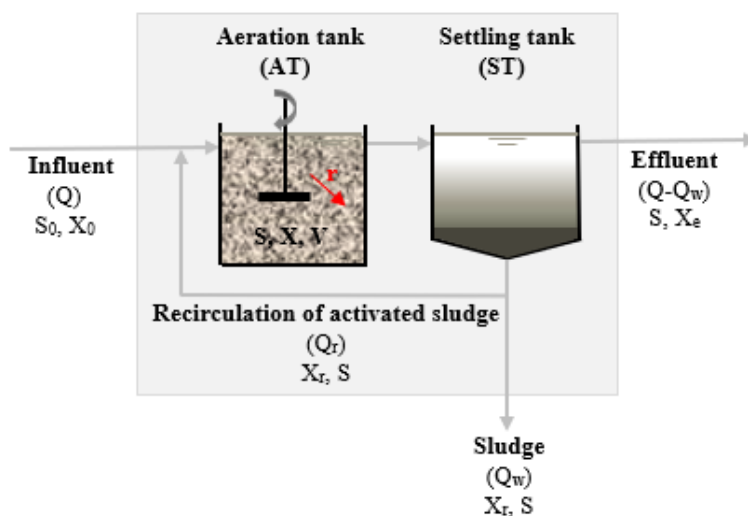

Where:

Q - influent (m^3/d),

Q_r - recirculation sludge flow (m^3/d),

Q_w - waste sludge flow (m^3/d),

S_0 (S_s) - concentration of biodegradable organic matter ($\text{g COD}/\text{m}^3$),

S - concentration of biodegradable organic matter in AT ($\text{g BOD}/\text{m}^3$),

X_0 - biomass concentration of influent ($\text{g VSS}/\text{m}^3$),

X - biomass concentration in AT (g/m^3),

X_r - biomass concentration of recirculation sludge (g/m^3),

X_e - biomass concentration of effluent (gVSS/m^3),

V - volume of reactor (AT) (m^3),

r (r_x, r_c) - net biomass growth rate ($\text{g VSS}/\text{m}^3, \text{d}$).

Fig. 1 Scheme of activated sludge process (Metcalf & Eddy 2014, Serdarevic and Dzubur 2016)

(Rieger *et al.* 2013, Serdarević and Džubur 2016). Both approaches have their own significant place in use. An example of guidelines for static modelling of WWTPs is the German ATV-A 131 (ATV-A 131, 2000) and its innovated guideline DWA-A131 (DWA-A 131 2016) are commonly used in practice. Dynamic modelling is a newer approach, which is related to the development of computer technology. It is more used in North-America than in Europe (Hauduc *et al.* 2009, Džubur and Serdarevic 2020). This approach is mostly used for process optimization, improvement of treatment effects, fine-tuning in plant operation etc. For example, you could not meaningfully use steady state modelling to assess how a WWTP design would handle a storm event. Dynamic modelling is the best way to provide an assessment of performance under these conditions. Alex *et al.* concluded that dynamic simulation can be used besides for integrated planning of WWTPs, mechanical equipment and control, also for the automation system and its “virtual commissioning” (Alex *et al.* 2020).

Philips and others 2009 recommend that in addition to adopting and generating the dynamic of WWTPs influent, a comparison of the results of the output model static versus the dynamic approach be performed, especially if sludge retention time (SRT) values are low (Phillips 2002).

Each of the approaches is based on a representation of reality but does not completely correspond to it. The difference (static vs. dynamic) can be shown based on the mass balance in the reactor (Fig. 1).

Physical, chemical and biological processes take place inside the reactor during wastewater treatment. Mass balance analysis is a basic approach used to describe the changes that occur when a reaction takes place in a reactor (Metcalf & Eddy 2014). Applying this analysis, the differences between approaches that neglect or do not neglect the time component can be clearly described.

For the mass balance it is a combination of: degradable matter, transport processes and reaction mechanisms (Jeppson 1996). For the completely mixed reactor, mass balance i.e., change in mass is equal to the sum of transport term and conversion term (Metcalf and Eddy 2014, Serdarević and Džubur 2016)

$$\frac{dM}{dt} = \frac{dc}{dt} \times V = (Q_{in} \times c_{in} - Q_{out} \times c_{out}) \times r_c \times V \quad (1)$$

In steady state calculation the term which describes the change of mass is equal to zero. The balance of mass simplifies the equation and equalizes the transport term with the conversion term.

$$Q_{in} \times c_{in} - Q_{out} \times c = -r_c \times V \quad (2)$$

$$r_c = \frac{Q_{out} \times c - Q_{in} \times c_{in}}{V} \quad (3)$$

Where:

c - concentration (g/m³), V - volume (m³), Q - flow (m³/s), r_c - net rate of biomass production, g VSS/m³, d , in - inlet to aeration tank (AT), out - outlet from AT.

Different types of models are used to describe the treatment process such as 0-D, 1-D or CFD models. The choice of the model depends on what is simulated and in how much detail (Rieger *et al.* 2013). In the last 20 years there has been a development and frequent application of CFD models and algorithms that show successful 3D simulations of turbulent flows in hydraulic structures (Wang and Yan 2018).

2. Materials and methods

For static modelling of WWTPs the necessary input data are the plant capacity (in PE) or flow

and parameters of influent composition. For newly planned WWTPs, a minimum number of inputs data is usually available. By adopting assumptions, constrains and safety coefficients, the flow of calculations and dimensioning can be monitored according the ATV protocol (Fig. 2).

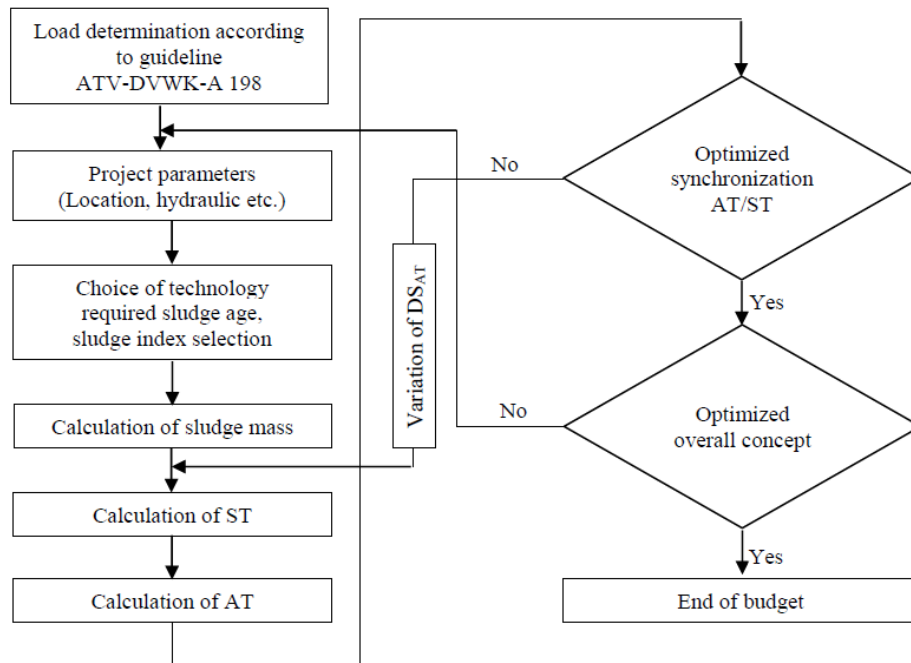

Fig. 2 Flowchart of planning and dimensioning process (ATV-A 131, 2000 and DWA-A 131, 2016)

*ST - settling tank, AT - aeration tank

For dynamic modelling of WWTPs, in addition to the basic input data on the connected inhabitants to the sewerage system, it is necessary to have a number of inlet data for its implementation. Flow and composition of wastewater can be measured or generated by different methods. One such method is “HSG-Sim” (“Hochschulgruppe Simulation”) (Spering *et al.* 2008). It is used for generation of diurnal variation for influent data and is incorporated in the simulator SIMBA#, from “Ifak Institute”, Magdeburg, Germany (<https://www.ifak.eu/en>), which is also used for holistic modelling of wastewater (Schütze *et al.* 2002). This method has been applied to several WWTPs from B&H, in order to generate daily influent variation for dynamic modelling (Dzubur and Serdarevic 2020).

Nowadays, a large number of computer programs are commercially available and are widely used for the design and operation of wastewater facilities. This allows the designer to compare different technologies and strategies with a speed that was not possible in the past.

Since the sequence of procedures in the application of dynamic modelling is not simple, some of the guidelines are usually used. Different guidelines can be found, researched and created for a sequence of specific conditions with a focus on different aspects of simulation projects. Some of the guidelines are: STOWA, BIOMATH, WERF, HSG, GMP etc. (Schütze *et al.* 2002, Dzubur and Serdarevic 2020). The GMP guidelines (Good Modeling Protocol) published by the IWA Task

Group (Rieger *et al.* 2013) cover the advantages of many earlier protocols. This protocol consists of 5 steps: (1) Project definition, (2) Datacollection and reconsilation, (3) Plant model set-up, (4) Calibration and validation and (5) Simulation and result interpretation. One of the clearest ways to display the protocol is according to the flowchart (Rieger *et al.* 2013). Since dynamic modelling is time consuming, it is important to estimate how much time to devote to each of the steps. Hauduc and others came up with time-consuming percentages for the application of dynamic modelling and implementation of all individual protocol steps, from 1-5. Each of the steps requires time in the amount of: 5%, 28%, 12%, 27% and 28% respectively (Hauduc *et al.* 2009). There are certain deviations, depending on the purpose of modelling and the type of organization (universities and colleges, government institutions or private companies). A similar approach can also be applied to drinking water treatment (Jusic and Milasonovic 2015, Jusic *et al.* 2019).

In general, the same procedures for static and dynamic access are used to define the input parameters (Alex *et al.* 2015). Some research is based on establishing a link between the two researches. The goal is to implement modelling with a static approach with significantly less complexity, and in parallel with the calculation to implement certain controls based on dynamic foundations. In a coupled calculation, the goal is to maintain a consistent connection between static calculation (according to DWA-Regelwerk) and dynamic simulation (Alex *et al.* 2015).

A dynamic modelling approach is introducing an increasing number of plant projects. The old German guidelines ATV-A 131 (ATV-A 131 2000), base the plant calculation on the influent BOD₅ parameter (parameter that cannot be balanced). However, activated sludge models, such as ASM models, are based on the COD parameter.

Basing the plant calculation on the COD parameter with the new guideline (DWA-A 131 2016), it is possible to compare the calculation (steady state) and the model of activated sludge (dynamic) (Alex *et al.* 2015). This advantage has just been used, and a comparative analysis of both approaches has been done for the WWTP Butila.

The aim of this paper was to show the general differences in approaches - static and dynamic modelling of WWTPs, on the example of WWTP Butila.

3. Results and discussion

3.1 Establishment of a WWTP database in B&H

Some urban centres in B&H built WWTPs more than three decades ago, such as Sarajevo (in 1982). Unfortunately, the development and construction of the WWTPs in B&H did not follow the developments in the developed countries of the world. The issue of wastewater treatment has been seriously reactivated in the last 15 years, and efforts are being made to improve the condition of drainage and wastewater treatment.

The historical development of the municipal WWTPs in B&H that are in operation can be followed during 10 years, according to Table 1.

Considering the increase in the number of plants in operation, it was proposed a the doctoral thesis (Džubur 2021) to form a database for the systematization of wastewater treatment plants (register of WWTPs). The WWTPs database in B&H could have multiple benefits in terms of development and improvement in this area.

There is a total of 25 municipal wastewater treatment plants in B&H to date. Of the total number of plants, 16 are in operation, of which 9 belong to the Sava River Basin and 7 to the Adriatic Basin.

Table 1 Historical development of WWTP in B&H, from 2010 to 2020

Situation 2010*			Situation 2020*		
No.	Basin area	WWTP	No.	Basin area	WWTP
1	Sava River Basin	Gradačac	1	Sava River Basin	Gradačac
2		Srebrenik	2		Srebrenik
3		Trnovo	3		Trnovo
4		Žepče	4		Žepče
5	Adriatic Sea Basin	Čitluk	5	Adriatic Sea Basin	Bihac
6		Grude	6		Odžak
7		Neum	7		Živinice
			8		Butila/Sarajevo
			9		Bijeljina
			10		Trebinje
			11		Bileća
		12	Čitluk		
		13	Grude		
		14	Konjic		
		15	Ljubuški		
		16	Neum		

* Data according to the competent institutions: Federal Ministry of Environment and Tourism, The Agency for the Sava River Basin, The Agency for the Adriatic Sea Basin, Public institution „Vode Srpske” Bijeljina, FB&H Environmental Protection Fund.

One of these 7 plants is WWTP Neum which has been added to this group, although it is located in the Republic of Croatia. Most of the facilities that were built and in operation in the pre-war period have been reconstructed and are in function today. According to official data from the Federal Ministry of Agriculture, Water Management and Forestry, about 40% of the Federation B&H population is connected to WWTPs.

Collection and systematization of databases on WWTPs and their operation requires the engagement and active involvement of several institutions in implementation. Therefore, in addition to the analysis of WWTP data, the issue of establishing a database of facilities in B&H and their operation is also raised. Considering that the competencies for monitoring the operation of plants are lowered to the entity level, i.e., for Federation of B&H to two water agencies (Adriatic Basin and Sava River Basin), the logical sequence would be to keep the database of WWTPs in this way. An example is the Project “IPA Program of the European Union 2011 - Capacity Building in the Water Sector in B&H” (<https://www.eptisasee.com/category/bosnia-and-herzegovina/>). The fifth point of this Project is: “Preparation of the Action Plan for the Development of the Water Information System”. An assessment of the state of the existing water information systems was made with special emphasis on the quality of hardware and software, system applications, compatibility of data collection and exchange methodology etc., and also editing data needed to support the International Commission of Sava River Basin and the International Commission for the Protection of the Danube River. The project aimed to provide technical assistance to institutions responsible for water resources management in B&H in order to meet the obligations and requirements of the European Union (EU) and domestic legislation. The main goals of the Project are: improving the provision of

information services and products, supporting institutional networking, managing and valuing information as assets, investments, strengthening the risk insurance system, etc.

3.2 Comparison of different modelling approaches-The example of WWTP Butila

The WWTP Butila was built for the first time in 1982 (Vojinović 2011).

During the war in B&H (1992-1995) it was devastated and in 2016 reconstructed for the first phase with capacity of 600,000 PE (Fig. 3).

Considering that the WWTP Butila was built in the first phase by applying mechanical and biological treatment, after a few years of operation of the plant, the following question arose: “When and how to carry out future expansion of WWTP including tertiary treatment?”. In accordance with the legislation, the capacity of the plant largely requires the inclusion of tertiary treatment. More details about the plant, input data, measurement techniques and treatment processes can be found in previously published papers (Džubur and Serdarević 2018, Serdarevic and Džubur 2019).

Modelling and simulation of WWTP Butila operation was performed with static and dynamic approaches, using the software packages Aqua Designer 8.1 (BitControl), shown on the Fig. 4 and GPS-X (Hydromantis), Fig. 5.

For the WWTP Butila the volume of the aeration tank (AT) is analysed and calculated. According to the project (I phase) V_{AT} is 21,980 m³ (As Built Project - WWTP Butila 2016). The calculation done in Aqua Designer 8.1 (see Fig. 4) resulted in a higher volume value, i.e., 23,204 m³ (+5.5%). The future expansion of the plant (II phase) is planned for 2030, including the removal of nutrients.



Fig. 3 View of WWTP Butila (<https://youtu.be/w8nA-Fb:0nU>, accessed 21.06.2019)

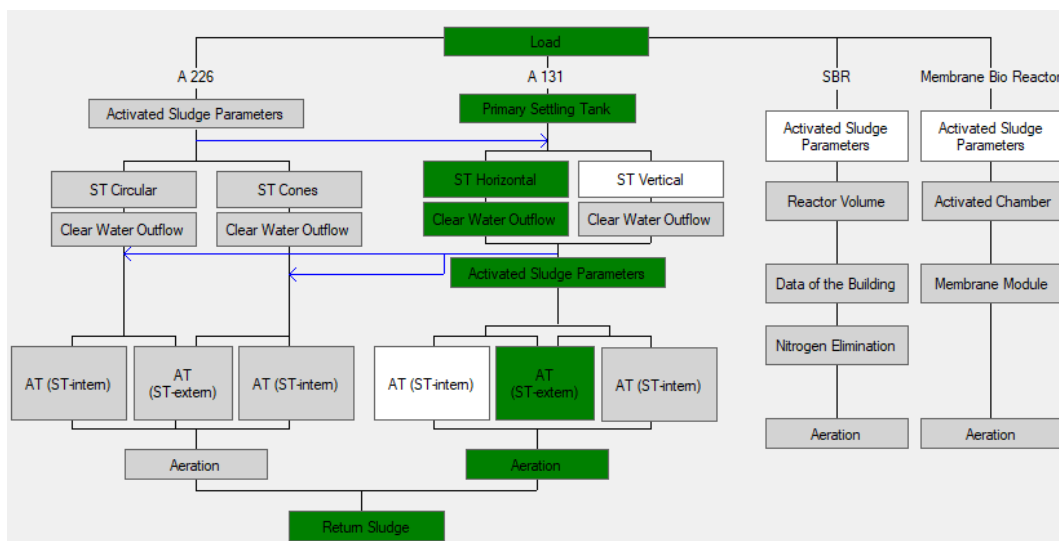

Fig. 4 WWTP Butila - Model in Aqua Designer 8.1

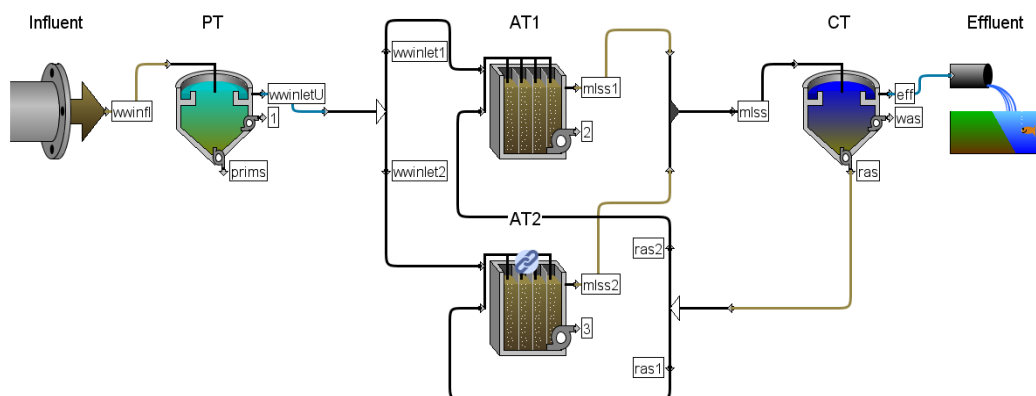

Fig. 5 WWTP Butila - Model in GPS-X

The project calculated that the volume of the aeration tanks should be 106,393 m³ and 108,604 m³ according the guideline DWA-A 131 (+2.1%). The differences are minor than for I phase, but the ratio of denitrification zone in relation to the total volume (V_D/V_{AT}) differs for 35-40%.

In opposite to static modelling, the results of aeration system optimization with dynamic modelling and possible future scenarios of the plant operation were obtained in regarding changes in the flow of influent and wastewater composition.

Dynamic modelling was first applied to WWTP Butila about 10 years ago. This research on WWTP Butila (Vojinović 2011) has shown the expediency of applying mathematical modelling. It is based on the input of the devastated plant, which required reconstruction, immediately before the decision-making process with regard to investments in urban infrastructure. Previous research is retained compromise between the priorities of investment and environmental benefits.

Nevertheless, dynamic modelling is commonly used for the expansion and upgrading of the WWTP. In this case, input data are available on the quantities and composition of wastewater, at the

Table 2 Input data requirements for WWTP Sarajevo (Butila)

Input data WWTP	Sarajevo (I phase) Project (1)	Sarajevo (I phase) measuring 2019 (2)	General data requirements for modelling	
			steady state	dynamic
PE (Pollutant equivalent)	600,000	-	necessary	necessary/preferable
Q _{ADWF} (m ³ /dan)	169,500.00	140,159.45	preferable	necessary
COD (g/m ³)	424.80	569.14	preferable	necessary
TSS (g/m ³)	247.80	338.35	preferable	necessary
TKN (g/m ³)	38.90	29.22	preferable	necessary
TP (g/m ³)	6.40	5.76	preferable	necessary
Oscillations of the influent flow and quality parameters during hours and days	-	-	unnecessary	necessary*

PE - Pollutant equivalent, Q_{ADWF} - Average dry weather flow, COD - Chemical oxygen demand, TKN - Total Kjeldahl Nitrogen, TP - Total phosphorus, f_{Qinf} - Fraction of infiltration water/total flow (-)

* how detailed and which parameter depending on the goal of modelling

(1) Project (As Built Project - WWTP Butila, 2016); (2) - (Dzubur & Serdarevic, 2020)

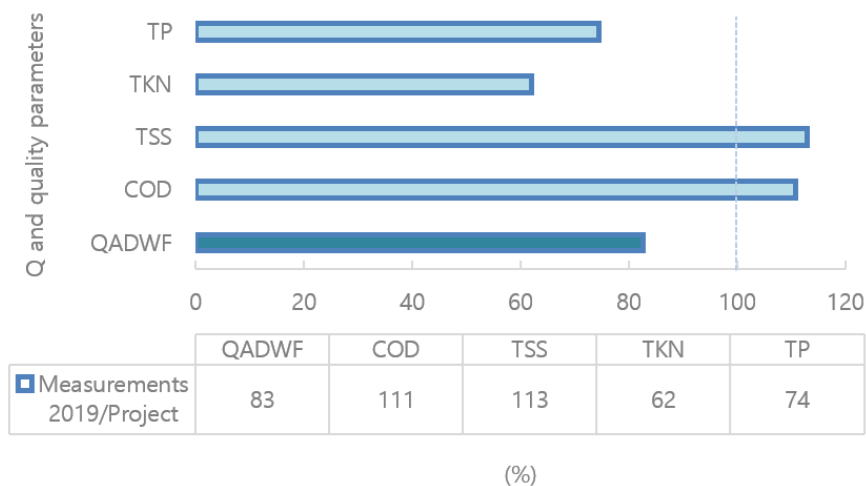

Fig. 6 The ratio of the mean values of measurements in 2019 and the values from the Project

inlet and outlet of the plant, and even in some places within the plant. Dynamic simulations were performed using the GPS-X simulator (see Fig. 5). Unlike static modelling, the results of requested and obtained goals refer to the optimization of the aeration system and the possible future scenarios of the plant regarding the change in quantity and composition of the influent wastewater.

General data requirements for modelling of WWTP Butila are presented in the Table 2. The input data of the key parameters of the raw wastewater are given there, for the I phase - actually of the 600,000 PE capacity according the Project (As Built Project - WWTP Butila 2016) and measurements in 2019.

In the column of modelling requirements from the previous table it was concluded that for the static modelling (in poor cases) necessary data is PE, and the other data are preferable, but not necessary. Unlike dynamic modelling, all this data is needed (even more for specific tasks,

depending on: How detailed it is modelled and what the issue is?) for successful calculation and dimensioning, as well as simulation for different strategies.

According to measurements, the average inflow of wastewater in 2019 is smaller (about 17%), but the values of COD and TSS increased compared to the Project (Fig. 6).

4. Conclusions

Static modelling is an adequate choice for planning new plants and it gives reliable results of facility dimensions (including sometimes significant reserves). Static simulators recommend a set of process coefficients, which can be adjusted, thus avoiding oversizing of facilities and equipment, while dynamic modelling is recommended for plants in operation and in the reconstruction or expansion phase. Their application is more adequate to describe the behavior of the treatment processes.

It is very important to analyze which of the approaches we should apply for plant modelling. It depends on a large number of factors. Static modelling has been applied in all previous WWTP projects, while dynamic modelling represents a new approach in B&H. This paper presents two general approaches: static and dynamic and both of them were used for modelling of the existing WWTP Butila, which is in function.

The total number of WWTPs in function over 5,000 PE in B&H is 16 and this indicates that it is time to use a “deeper” modelling approach that will, in addition to the dimensions of facilities and equipment, explore the treatment processes themselves, possible scenarios on WWTP etc.

An important project, whose focus of research is modelling WWTPs, is a PhD thesis at the Faculty of Civil Engineering, University in Sarajevo (Džubur, 2021). By implementing static modelling in this research using the Aqua Designer 8.1 program and according to the recommended flow chart of the DWA-A 131 guidelines, it confirmed the justification of the use of static models for the design of new plants. The calculation obtained the dimensions of aeration tank with slight deviations compared to the projected values. However, the application of static modelling does not give a state of the biokinetics and processes that take place inside the reactor, and whose knowledge can affect the quality of plant operation and system optimization.

The main obstacles to the application of dynamic modelling are: cost, time, complexity and applicability of an adequate model. The end result is improvement in the plant operation processes, savings in building dimensions and optimization of plant equipment.

A recommendation was also made for the introduction of a serious database of WWTPs, which would be available to experts and researchers for project implementation. In this way, the necessary and/or preferably input data for research, including plant modelling, could be provided in a significantly more favourable and efficient way.

Acknowledgments

Data relating to the WWTPs in B&H were established with the competent institutions: Federal Ministry of Environment and Tourism, The Agency for the Sava River Basin, The Agency for the Adriatic Sea Basin, Public institution “Vode Srpske” Bijeljina, FB&H Environmental Protection Fund. Input data for modelling, i.e., flow and water quality parameters, are ceded from municipal utilities of Sarajevo (ViK Sarajevo) with the support of the plant employees.

References

- Alex, J., Ahnert, M., Dürrenmatt, D.J., Langergraber, G., Hobus, I., Schmuck, S. and Spering, V. (2015), "Voraussetzungen für eine dynamische Simulation als Bestandteil einer statischen Kläranlagenbemessung nach DWA-A 131", *Korrespondenz Abwasser* 2015, **62**(5), 436-446. <http://doi.org/10.3242/kae2015.05.003>.
- Alex, J., Hübner, C. and Förster, L. (2020), "Planning, testing and commissioning of automation solutions for waste water treatment plants using simulation", *21st IFAC World Congress*, IFAC Magdeburg, Germany, July.
- As Built Design - Reconstruction Works at Sarajevo Wastewater Treatment Plant at Butila (2016), "Unioninvest" d.d. Sarajevo and "Passavant, Energy & Environment".
- ATV-DVWK-A 131E (2000), German ATV-DVWK Rules and Standards, Dimensioning of Single-Stage Activated Sludge Plants, German Association for Water, Wastewater and Waste, Hennef, Germany.
- ATV-DWA-A 131 (2016), German DWA-Regelwerk, Rules and Standards, Dimensioning of single-Stage Activated Sludge Plants, German Association for Water, Wastewater and Waste, Hennef, Germany.
- Džubur, A. (2021), "Primjena dinamičkih simulacija na postrojenja za prečišćavanje komunalnih otpadnih voda sa aktivnim muljem", PhD Thesis, Faculty of Civil Engineering, University of Sarajevo, Sarajevo, Bosnia and Herzegovina.
- Džubur, A. and Serdarević, A. (2018), Kontrola i održavanje PPOV - Primjer PPOV Butile, Sarajevo, BiH, 5. Konferencija "Održavanje 2018", Zenica, May.
- Dzubur, A. and Serdarevic, A. (2020), "Daily influent variation for dynamic modelling of wastewater treatment plants", *Couple. Syst. Mech.*, **9**(2), 111-123. <https://doi.org/10.12989/csm.2020.9.2.111>.
- Hauduc, H., Gillot, S., Rieger, L., Ohtsuki, T., Shaw, A., Takacs, I. and Winkler, S. (2009), "Activated sludge modelling in practice: an international survey", *Water Sci. Technol.*, **60**(8), 1943-1951. <http://doi.org/10.2166/wst.2009.223>.
- Jeppsson, U. (1996), "A general description of the activated sludge model No. 1 (ASM1)", PhD Thesis, Lund Institute of Technology, Lund University, Sweden.
- Jusic, S. and Milasinovic, Z. (2015), "Model based control of filter run time on potable water treatment plant", *Couple. Syst. Mech.*, **4**(2), 157-172. <http://doi.org/10.12989/csm.2015.4.2.157>.
- Jusic, S., Milasinovic, Z., Milisic, H. and Hadzic, E. (2019), "Models for drinking water treatment processes", *Couple. Syst. Mech.*, **8**(6), 489-500. <http://doi.org/10.12989/csm.2019.8.6.489>.
- Metcalf & Eddy (2014), *Wastewater Engineering, Treatment and Resource Recovery*, Fifth Edition, McGraw-Hill Education, New York.
- Phillips, H.M., Sahlstedt, K.E., Frank, K., Bratby, J., Brennan, W., Rogowski, S., Pier, D., Anderson, W., Mulas M., Copp, J.B. and Shirodkar, N. (2009), "Wastewater treatment modelling in practice: a collaborative discussion of the state of the art", *Water Sci. Technol.*, **59**(4), 695-704. <http://doi.org/10.2166/wst.2009.591>.
- Rieger, L., Gillot, S., Langergraber, G., Ohtsuki, T., Shaw, A., Takács, I. and Winkler, S. (2013), *IWA Task Group on Good Modelling Practice-Guidelines for Use of Activated Sludge Models*, IWA Publishing, London, UK.
- Schütze, M., Butler, D. and Beck, M.B. (2002), *Modelling, Simulation and Control of Urban Wastewater Systems*, Springer-Verlag, London, UK.
- Serdarevic, A. and Dzubur, A. (2016), "Wastewater process modeling", *Couple. Syst. Mech.*, **5**(1), 21-39. <http://doi.org/10.12989/csm.2016.5.1.021>.
- Serdarevic, A. and Dzubur, A. (2019), "Importance and practice of operation and maintenance of wastewater treatment plants", *International Symposium on Innovative and Interdisciplinary Applications of Advanced Technologies*, June.
- Spering, V., Alex, J., Langergraber, G., Ahnert, M., Halft, N., Hobus, I., Weissenbacher, N., Winkler, S. and Yücesoy, E. (2008), "Using dynamic simulation for design of activated sludge plants", *Proceedings of the International Symposium on Sanitary and Environmental Engineering - SIDISA.08*, Florence, Italy, June.

- Vojinović, Z. and Price, R.K. (2011), *Urban Hydroinformatics: Data, Models and Decision Support for Integrated Urban Water Management, Chapter 11: Wastewater Treatment*, IWA Publishing, London, UK.
- Wang, W. and Yan, Y. (2018) "Simulation of turbulent flow of turbine passage with uniform rotating velocity of guide vane", *Couple. Syst. Mech.*, **7**(4). 421-440. <https://doi.org/10.12989/csm.2018.7.4.421>